

## DECLARATION OF CONFORMITY

Hereby, NOKIA CORPORATION declares that the RM-364, RM-365 and RM-366 product is in compliance with the essential requirements and other relevant provisions of Directive 1999/5/EC. A copy of the Declaration of Conformity can be found at [http://www.nokia.com/phones/declaration\\_of\\_conformity/](http://www.nokia.com/phones/declaration_of_conformity/).

# CE 0434

Copyright © 2009 Nokia. All rights reserved.

Nokia, Nokia Connecting People, Navi and Visual Radio are trademarks or registered trademarks of Nokia Corporation. Nokia tune is a sound mark of Nokia Corporation. Other product and company names mentioned herein may be trademarks or tradenames of their respective owners.

Reproduction, transfer, distribution, or storage of part or all of the contents in this document in any form without the prior written permission of Nokia is prohibited.

US Patent No 5818437 and other pending patents. T9 text input software Copyright (C) 1997-2009. Tegic Communications, Inc. All rights reserved.



Includes RSA BSAFE cryptographic or security protocol software from RSA Security.



Java is a trademark of Sun Microsystems, Inc.

This product is licensed under the MPEG-4 Visual Patent Portfolio License (i) for personal and noncommercial use in connection with information which has been encoded in compliance with the MPEG-4 Visual Standard by a consumer engaged in a personal and noncommercial activity and (ii) for use in connection with MPEG-4 video provided by a licensed video provider. No license is granted or shall be implied for any other use. Additional information, including that related to promotional, internal, and commercial uses, may be obtained from MPEG LA, LLC. See <http://www.mpegla.com>.

Nokia operates a policy of ongoing development. Nokia reserves the right to make changes and improvements to any of the products described in this document without prior notice.

TO THE MAXIMUM EXTENT PERMITTED BY APPLICABLE LAW, UNDER NO CIRCUMSTANCES SHALL NOKIA OR ANY OF ITS LICENSORS BE RESPONSIBLE FOR ANY LOSS OF DATA OR INCOME OR ANY SPECIAL, INCIDENTAL, CONSEQUENTIAL OR INDIRECT DAMAGES HOWSOEVER CAUSED.

THE CONTENTS OF THIS DOCUMENT ARE PROVIDED "AS IS". EXCEPT AS REQUIRED BY APPLICABLE LAW, NO WARRANTIES OF ANY KIND, EITHER EXPRESS OR IMPLIED, INCLUDING, BUT NOT LIMITED TO, THE IMPLIED WARRANTIES OF MERCHANTABILITY AND FITNESS FOR A PARTICULAR PURPOSE, ARE MADE IN RELATION TO THE ACCURACY, RELIABILITY OR CONTENTS OF THIS DOCUMENT. NOKIA RESERVES THE RIGHT TO REVISE THIS DOCUMENT OR WITHDRAW IT AT ANY TIME WITHOUT PRIOR NOTICE.

The availability of particular products and applications and services for these products may vary by region. Please check with your Nokia dealer for details and availability of language options.

## Export controls

This device may contain commodities, technology or software subject to export laws and regulations from the US and other countries. Diversion contrary to law is prohibited.

The third-party applications provided with your device may have been created and may be owned by persons or entities not affiliated with or related to Nokia. Nokia does not own the copyrights or intellectual property rights to the third-party applications. As such, Nokia does not take any responsibility for end-user support, functionality of the applications, or the information in the applications or these materials. Nokia does not provide any warranty for the third-party applications.

BY USING THE APPLICATIONS YOU ACKNOWLEDGE THAT THE APPLICATIONS ARE PROVIDED AS IS WITHOUT WARRANTY OF ANY KIND, EXPRESS OR IMPLIED, TO THE MAXIMUM EXTENT PERMITTED BY APPLICABLE LAW. YOU FURTHER ACKNOWLEDGE THAT NEITHER NOKIA NOR ITS AFFILIATES MAKE ANY REPRESENTATIONS OR WARRANTIES, EXPRESS OR IMPLIED, INCLUDING BUT NOT LIMITED TO WARRANTIES OF TITLE, MERCHANTABILITY OR FITNESS FOR A

PARTICULAR PURPOSE, OR THAT THE APPLICATIONS WILL NOT INFRINGE ANY THIRD-PARTY PATENTS, COPYRIGHTS, TRADEMARKS, OR OTHER RIGHTS.

9207931  
Issue 3.1

# Contents

<b>SAFETY</b> .....	<b>ix</b>	Indicators.....	11
<b>General information</b> .....	<b>xi</b>	Flight profile .....	12
About your device.....	xi	<b>2. Calls</b> .....	<b>14</b>
Network services .....	xii	Make a voice call.....	14
Enhancements.....	xiii	Answer or reject a call .....	15
Access codes.....	xiv	Speed dialling .....	15
Software updates.....	xvi	Options during a call .....	16
Download content .....	xvii	Make a video call.....	16
<b>1. Get started</b> .....	<b>1</b>	<b>3. Messaging</b> .....	<b>19</b>
Install SIM card and		Write and send a text	
battery.....	1	message.....	19
Charge the battery.....	2	Write and send a	
Switch the phone on		multimedia message.....	19
and off.....	3	Read and reply to a	
Set the time, zone,		message.....	20
and date.....	4	E-mail application.....	21
Configuration settings		E-mail setup wizard.....	21
service.....	4	Write and send e-mail ....	22
Antenna .....	5	Read and reply to	
Keys and parts.....	6	e-mail.....	23
microSD memory card .....	7	Message settings .....	24
Standby mode .....	9	General settings.....	24

Text messages .....	25	Connectivity .....	39
Multimedia messages .....	26	Connecting with	
E-mail messages .....	28	Bluetooth .....	40
<b>4. Contacts .....</b>	<b>29</b>	Activate a Bluetooth	
Save names and phone		connection .....	41
numbers .....	29	Connect a Bluetooth	
Add contact details .....	29	device .....	41
Search for a contact .....	30	View a list of your	
Copy or move contacts .....	30	Bluetooth connections .....	41
Edit contacts .....	31	Send data to a Bluetooth	
Groups .....	31	device .....	42
Contact settings .....	31	Hide your Bluetooth	
<b>5. Log .....</b>	<b>33</b>	device from others .....	42
<b>6. Settings .....</b>	<b>34</b>	Synchronise from a	
Profiles .....	34	compatible PC .....	42
Themes .....	34	Synchronise from a	
Tones .....	35	server .....	43
Display .....	35	USB data cable .....	43
Standby mode settings .....	35	Call .....	44
Date and time .....	37	Phone .....	45
My shortcuts .....	37	Enhancements .....	47
Left selection key .....	38	Configuration .....	48
Right selection key .....	38	Restore factory settings .....	49
Navigation key .....	38	Phone software updates .....	49
Active standby key .....	38	<b>7. PC connectivity .....</b>	<b>51</b>
Sync and backup .....	39	Nokia PC Suite .....	51

## Contents

Data communication applications .....	51	Care and maintenance .....	69
<b>8. Media .....</b>	<b>53</b>	<b>Additional safety information.....</b>	<b>71</b>
Camera .....	53	Small children.....	71
Take an image .....	53	Operating environment.....	71
Video .....	53	Medical devices.....	72
Record a video clip .....	54	Implanted medical devices .....	72
Music player .....	54	Hearing aids .....	73
Radio.....	55	Vehicles .....	73
<b>9. Battery and charger information.....</b>	<b>59</b>	Potentially explosive environments.....	74
Nokia battery authentication guidelines .....	62	Emergency calls .....	75
<b>10. Nokia original enhancements.....</b>	<b>65</b>	To make an emergency call:.....	76
BATTERY .....	66	Certification information (SAR).....	77
Headsets .....	66	<b>MANUFACTURER'S LIMITED WARRANTY ...</b>	<b>79</b>
Wireless Headsets .....	66	<b>Index.....</b>	<b>86</b>
Wired Headsets.....	67		
Car Solutions .....	67		
Plug-in Solution .....	67		
Data.....	68		
Memory Cards.....	68		

# SAFETY

Read these simple guidelines. Not following them may be dangerous or illegal. Read the complete user guide for further information.



## SWITCH ON SAFELY

Do not switch the device on when wireless phone use is prohibited or when it may cause interference or danger.



## ROAD SAFETY COMES FIRST

Obey all local laws. Always keep your hands free to operate the vehicle while driving. Your first consideration while driving should be road safety.



## INTERFERENCE

All wireless devices may be susceptible to interference, which could affect performance.



## SWITCH OFF IN RESTRICTED AREAS

Follow any restrictions. Switch the device off in aircraft, near medical equipment, fuel, chemicals, or blasting areas.

## SAFETY



### **QUALIFIED SERVICE**

Only qualified personnel may install or repair this product.



### **ENHANCEMENTS AND BATTERIES**

Use only approved enhancements and batteries. Do not connect incompatible products.



### **WATER-RESISTANCE**

Your device is not water-resistant. Keep it dry.

# General information

## ■ About your device

The wireless device described in this guide is approved for use on the WCDMA 850 and 2100 (RM-364), WCDMA 900 and 2100 (RM-365), WCDMA 850 and 1900 (RM-366), and GSM 850, 900, 1800, and 1900 networks. Contact your service provider for more information about networks.

When using the features in this device, obey all laws and respect local customs, privacy and legitimate rights of others, including copyrights.

Copyright protection may prevent some images, music, and other content from being copied, modified, or transferred.

Your device may have preinstalled bookmarks and links for third-party internet sites. You may also access other third-party sites through your device. Third-party sites are not affiliated with Nokia, and Nokia does not endorse or assume liability for them. If you choose to access such sites, you should take precautions for security or content.

## General information



**Warning:** To use any features in this device, other than the alarm clock, the device must be switched on. Do not switch the device on when wireless device use may cause interference or danger.

Remember to make back-up copies or keep a written record of all important information stored in your device.

When connecting to any other device, read its user guide for detailed safety instructions. Do not connect incompatible products.

## ■ Network services

To use the phone you must have service from a wireless service provider. Many of the features require special network features. These features are not available on all networks; other networks may require that you make specific arrangements with your service provider before you can use the network services. Your service provider can give you instructions and explain what charges will apply. Some networks may have limitations that affect how you can use

network services. For instance, some networks may not support all language-dependent characters and services.

Your service provider may have requested that certain features be disabled or not activated in your phone. If so, these features will not appear on your phone menu. Your phone may also have a special configuration such as changes in menu names, menu order, and icons. Contact your service provider for more information.

This device supports WAP 2.0 protocols (HTTP and SSL) that run on TCP/IP protocols. Some features of this device, such as multimedia messaging (MMS), browsing, e-mail application, instant messaging, remote synchronisation, and content downloading using the browser or MMS, require network support for these technologies.

### ■ Enhancements



**Warning:** Use only batteries, chargers, and enhancements approved by Nokia for use with this particular model. The use of any other types may

## General information

invalidate any approval or warranty, and may be dangerous.

For availability of approved enhancements, please check with your dealer. When you disconnect the power cord of any enhancement, grasp and pull the plug, not the cord.

### ■ Access codes

Select **Menu** > *Settings* > *Security* to set how your phone uses the access codes and security settings.

- To prevent accidental key presses, use the keypad lock (keyguard).

Select **Menu** > *Settings* > *Phone* > *Automatic keyguard* or *Security keyguard* > *On* or *Off*. If the *Security keyguard* is set *On*, enter a security code of your choice when requested.

To unlock the keys, select **Unlock**, and press the \* key.

To answer a call when the keyguard is on, press the call key. When you end or reject the call, the keys are automatically locked.

## General information

- The security code helps to protect your phone against unauthorised use.
- The PIN code, supplied with the SIM card, helps to protect the card against unauthorised use.
- The PIN2 code, supplied with some SIM cards, is required to access certain services.
- PUK and PUK2 codes may be supplied with the SIM card. If you enter the PIN or PIN2 code incorrectly three times in succession, you will be asked for the PUK or PUK2 code. If you do not have them, contact your service provider.
- The barring password (four digits) is required when using the *Call barring service* to restrict calls to and from your phone (network service).
- To view or change the security module settings, if installed, select **Menu** > *Settings* > *Security* > *Security module sett.*

## ■ Software updates



**Important:** Use only services that you trust and that offer adequate security and protection against harmful software.

Nokia may produce software updates that may offer new features, enhanced functions, or improved performance. You may be able to request these updates through the Nokia Software Updater PC application. To update the device software, you need the Nokia Software Updater application and a compatible PC with Microsoft Windows 2000, XP, or Vista operating system, internet access, and a compatible data cable to connect your device to the PC.

To get more information and to download the Nokia Software Updater application, visit [www.nokia-asia.com/softwareupdate](http://www.nokia-asia.com/softwareupdate) or your local Nokia website.

Downloading software updates may involve the transmission of large amounts of data through your service provider's network. Contact your service provider for information about data transmission charges.

Make sure that the device battery has enough power, or connect the charger before starting the update.

If software updates over the air are supported by your network, you may also be able to request updates through the device. See "Phone," p. 45.

### ■ Download content

You may be able to download new content (for example, themes) to your phone (network service).

For the availability of different services, pricing, and tariffs, contact your service provider.



**Important:** Use only services that you trust and that offer adequate security and protection against harmful software.

## General information

# 1. Get started

## ■ Install SIM card and battery

Always switch the device off and disconnect the charger before removing the battery.

The SIM card and its contacts can easily be damaged by scratches or bending, so be careful when handling, inserting, or removing the card. Insert the SIM card with the gold-coloured contact area facing down (6-7).

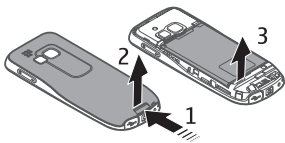

## Get started

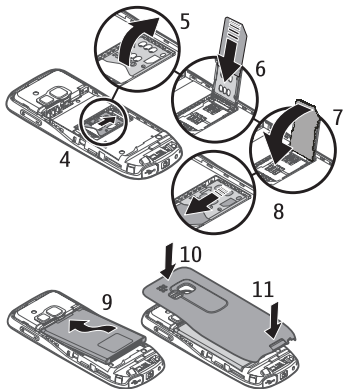

### ■ Charge the battery

Charging the BL-4U battery with the AC-3 charger takes approximately 2 hours 15 minutes while the phone is in the standby mode.

1. Connect the charger to a wall socket.
2. Connect the lead from the charger to the charger connector at the bottom of your phone.

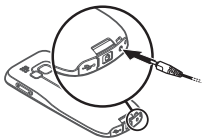

If the battery is completely discharged, it may take several minutes before the charging indicator appears on the display or before any calls can be made.

### ■ Switch the phone on and off

1. Press and hold the power key as shown.
2. If the phone asks for a PIN or a UPIN code, enter the code (for example, displayed as \*\*\*\*), and select **OK**.

When you switch on your phone for the first time, and the phone is in the standby mode, you are asked to obtain the configuration settings from your service provider (network service). Confirm



## Get started

or decline the query. See "Configuration," p. 48, and "Configuration settings service," p. 4.

### ■ Set the time, zone, and date

When you switch on your phone for the first time, the phone is in the standby mode, and you are asked to set the time and date. Fill in the fields, and select **Save**.

To access *Date and time* later, select **Menu** > *Settings* > *Date and time* > *Date & time settings*, *Date and time format*, or *Auto-update of time (network service)* to change the time, time zone, and date settings.

### ■ Configuration settings service

To use some of the network services, such as mobile internet services, MMS, Nokia Xpress audio messaging, or remote internet server synchronisation, your phone needs the correct configuration settings. For more information on availability, contact your network operator, service provider, nearest authorised Nokia dealer, or visit the

support area on the Nokia website, [www.nokia-asia.com/3120classic/support](http://www.nokia-asia.com/3120classic/support).

When you have received the settings as a configuration message, and the settings are not automatically saved and activated, *Configuration settings received* is displayed. Select **Show > Save**. If required, enter the PIN code supplied by the service provider.

## ■ Antenna

Your device may have internal and external antennas. As with any radio transmitting device, avoid touching the antenna area unnecessarily while the antenna is transmitting or receiving. Contact with such an antenna affects the communication quality and may cause the device to operate at a higher power level than otherwise needed and may reduce the battery life.



## Get started

### ■ Keys and parts

1. Front camera lens
2. Earpiece
3. Display
4. Left selection key
5. Right selection key
6. Call key
7. End key
8. Middle selection key
9. Keypad
10. Navi™ key (herein referred to as scroll key)

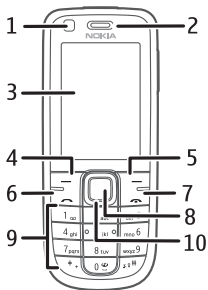

- 11. Microphone
- 12. Charger connector
- 13. Enhancements connector
- 14. USB connector

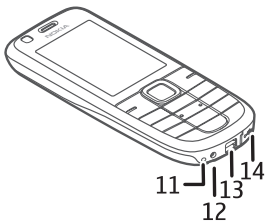

- 15. Camera lens
- 16. Camera flash
- 17. Power key
- 18. Loudspeaker
- 19. Volume up key/PTT
- 20. Volume down key

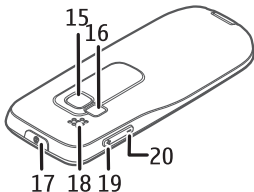

## ■ microSD memory card

The sales package of your device may not include a memory card. Memory cards are available as separate accessories.



## Get started

A microSD memory card can be loaded with data such as ringing tones, themes, tones, images and videos. If you delete, reload, or replace this card, these functions and features may not function properly.

Use only compatible microSD cards approved by Nokia for use with this device. Nokia uses approved industry standards for memory cards, but some brands may not be fully compatible with this device. Incompatible cards may damage the card and the device and corrupt data stored on the card.



**Important:** Do not remove the memory card in the middle of an operation when the card is being accessed. Removing the card in the middle of an operation may damage the memory card as well as the device, and data stored on the card may be corrupted.

1. Remove the battery cover of the phone. Insert the card with the gold-coloured contact area facing down (1).
2. Press the card into the slot until it clicks into place (2). Replace the battery cover.

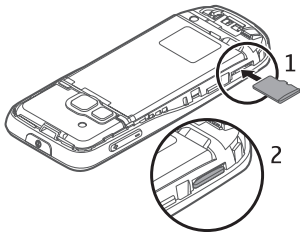

## ■ Standby mode

When the phone is ready for use, and you have not entered any characters, the phone is in the standby mode.

## Get started

1. 3G indicator
2. Signal strength of the cellular network
3. Battery charge level
4. Indicators. See "Indicators," p. 11.
5. Name of the network or the operator logo
6. Clock
7. Display
8. The left selection key is **Go to** or a shortcut to a function that you have selected. See "Left selection key," p. 38.
9. The middle selection key is **Menu**.
10. The right selection key may be **Names** to access the list of contacts in the *Contacts* menu, an operator-specific name to access an operator-specific website, or a shortcut to a function that you have selected. See "Right selection key," p. 38.

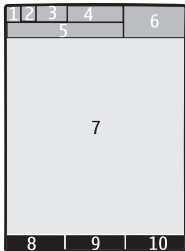

## Indicators



You have unread messages.



The phone registered a missed call. See "Log," p. 33.



The keypad is locked. See "Access codes," p. xiv.



The phone does not ring for an incoming call or text message when **Incoming call alert** and **Message alert tone** are set to **Off**. See "Tones," p. 35.



The alarm clock is set to **On**



The packet data connection mode, **Always online** is selected and the packet data service is available, the indicator is shown.



A GPRS or EGPRS connection is established.



The GPRS or EGPRS connection is suspended (on hold).

## Get started



Bluetooth connectivity is activated. See "Connecting with Bluetooth," p. 40.

## ■ Flight profile

You can deactivate all radio frequency functions and still have access to offline games, calendar, music player, and phone numbers. Use the flight profile in radio sensitive environments—on board aircraft or in hospitals. When the flight profile is active,  is shown.

Select **Menu** > *Settings* > *Profiles* > *Flight* > *Activate* or *Personalise*.

To set the phone to ask every time it is switched on whether to use the flight profile, select **Menu** > *Settings* > *Phone* > *Flight query* > *On* or *Off*.

To deactivate the flight profile, select any other profile.

In the offline or flight profiles, you may need to unlock the device and change to the calling profile before making a call.



**Warning:** With the flight profile you cannot make or receive any calls, including emergency calls, or use other features that require network coverage. To make calls, you must first activate the phone function by changing profiles. If the device has been locked, enter the lock code. If you need to make an emergency call while the device is locked and in the flight profile, you may be also able to enter an official emergency number programmed in your device in the lock code field and select 'Call'. The device will confirm that you are about to exit flight profile to start an emergency call.

## 2. Calls

### ■ Make a voice call

Do one of the following:

- Enter the phone number, including the area code if required, and press the call key.

For international calls, press \* twice for the international prefix (the + character replaces the international access code), enter the country code, the area code without the leading 0, if necessary, and the phone number.

- To list the last called numbers, press the call key once. To call one of the numbers, select it, and press the call key.
- Call a number saved in *Contacts*. See “Contacts,” p. 29.

To increase or decrease the volume during a call, press the volume key up or down.

## ■ Answer or reject a call

To answer a call, press the call key. To end the call, press the end key.

To reject a call, press the end key.

To mute the ringing tone, select **Silence**.

## ■ Speed dialling

To assign a number to one of the speed-dialling keys, 3 to 9:

1. Select **Menu** > *Contacts* > *Speed dials*.
2. Scroll to the speed-dialling number that you want.
3. Select **Assign**, or if a number has already been assigned to the key, select **Options** > *Change*.
4. Select **Search** and the contact you want to assign.

If the *Speed dialling* function is off, the phone asks whether you want to activate it.

Select **Menu** > *Settings* > *Call* > *Speed dialling* > *On* or *Off*.

## C a l l s

To call a number, press and hold a speed-dialling key until the call begins.

### ■ Options during a call

Many of the options that you can use during a call are network services. For availability, contact your service provider.

Possible options that your service provider may offer include conference calls, video sharing and placing calls on hold.

### ■ Make a video call

1. To start a video call, enter the phone number in the standby mode, or select **Contacts** and a contact.
2. Press and hold the call key, or select **Options** > *Video call*.

Starting a video call may take a while. *Video call* and an outgoing animation is shown. If the call does not succeed (for example, video calls are not supported by

the network, or the receiving device is not compatible), you are asked if you want to try a voice call or send a message instead.

To increase or decrease the volume during a call, press the volume key up or down.

3. To end the call, press the end key.

When you make a video call, you send a real-time video to the recipient of the call. The video image captured by the camera on the front of your phone is shown to the video call recipient.

To make a video call, you must have a USIM card and be connected to a WCDMA network. For availability of and subscription to video call services, contact your network operator or service provider. A video call can only be made between two parties. The video call can be made to a compatible phone or an ISDN client. Video calls cannot be made while another voice, video, or data call is active.

## C a l l s

During extended operation such as an active video call and high speed data connection, the device may feel warm. In most cases, this condition is normal. If you suspect the device is not working properly, take it to the nearest authorised service facility.

## 3. Messaging

### ■ Write and send a text message

1. Select **Menu** > *Messaging* > *Create message* > *Message*.
2. Enter one or more phone numbers in the *To:* field. To retrieve a phone number from a memory, select **Add**.
3. Write your message in the *Text:* field.  
To use a text template, scroll down, and select **Insert**.
4. Select **Send**.

### ■ Write and send a multimedia message

1. Select **Menu** > *Messaging* > *Create message* > *Message*.
2. Enter one or more phone numbers or e-mail addresses in the *To:* field. To retrieve a phone number or e-mail address from a memory, select **Add**.

## M e s s a g i n g

3. Write your message. To add a file, scroll down, and select **Insert**.
4. To view the message before sending it, select **Options > Preview**.
5. Select **Send**.

Only devices that have compatible features can receive and display multimedia messages. The appearance of a message may vary depending on the receiving device.

The wireless network may limit the size of MMS messages. If the inserted picture exceeds this limit, the device may make it smaller so that it can be sent by MMS.

To check availability and to subscribe to the multimedia messaging service (MMS, network service), contact your service provider.

### ■ Read and reply to a message

1. To view a received message, select **Show**.  
To read the message later, select **Menu > Messaging > Inbox**.

2. To reply to a message, select **Reply**. Write the reply message.
3. Select **Send**.



**Important:** Exercise caution when opening messages. Messages may contain malicious software or otherwise be harmful to your device or PC.

### ■ E-mail application

To activate the e-mail settings, select **Menu** > *Messaging* > *Message settings* > *E-mail messages*.

To use the e-mail function on your phone, you need a compatible e-mail system.

You may receive the e-mail configuration settings as a configuration message.

### E-mail setup wizard

Select **Menu** > *Messaging* > *E-mail* and enter your e-mail address.

## M e s s a g i n g

The e-mail application requires an internet access point without a proxy. WAP access points normally include a proxy and do not work with the e-mail application.

### Write and send e-mail

You can write your e-mail message before connecting to the e-mail service; or connect to the service first, then write and send your e-mail.

1. Select **Menu** > *Messaging* > *Create message* > *E-mail*.

If more than one e-mail account is defined, select the account from which you want to send the e-mail.

2. Enter the recipient's e-mail address, write the subject, and enter the message. To attach a file to the e-mail, select **Options** > *Insert*.

To save your e-mail, select **Options** > *Save message*. To edit or continue writing your e-mail later, select *As draft message*.

3. To send the e-mail message, select **Send**.

To send an e-mail from a draft folder, select **Menu** > *Messaging* > *Drafts* and the desired message.

## Read and reply to e-mail

1. Select **Menu** > *Messaging*, the account name, and the desired message.
2. To reply to an e-mail, select **Options** > *Reply*. Confirm or edit the e-mail address and subject, and create your reply.
3. To send the message, select **Send**.

To end the e-mail session, select **Options** > *Disconnect*.



**Important:** Exercise caution when opening messages. Messages may contain malicious software or otherwise be harmful to your device or PC.

### ■ Message settings

#### General settings

General settings are common for text and multimedia messages.

Select **Menu** > *Messaging* > *Message settings* > *General settings* and from the following options:

*Save sent messages* – to save the sent messages in the *Sent items* folder

*Overwrite sent items* – to overwrite the old sent messages with the new ones when the message memory is full. This setting is shown only if you selected *Save sent messages*.

*Favourite recipient* – to define easily available message recipients or groups when sending messages

*Font size* – to select the font size used in messages

*Graphical smileys* – to replace character-based smileys with graphical ones

## Text messages

The text message settings affect the sending, receiving, and viewing of text messages.

Select **Menu** > *Messaging* > *Message settings* > *Text messages*, and from the following options:

*Delivery reports* – to receive delivery reports about your messages (network service)

*Message centres* – to add a message centre that is required for sending text messages. You receive the phone number of the message centre from your service provider.

*Msg. centre in use* – to select the message centre in use

*Message validity* – to select the length of time for which the network attempts to deliver your message

*Messages sent via* – to select the format of the messages to be sent: *Text*, *Paging*, or *Fax* (network service)

*Use packet data* – to set GPRS as the preferred SMS bearer

*Character support* – to select how characters in the messages are sent. Select *Full* to send the characters as they are viewed.

## M e s s a g i n g

*Rep. via same centre* – to allow the recipient of your message to send you a reply using your message centre (network service)

## Multimedia messages

The message settings affect the sending, receiving, and viewing of multimedia messages. You may receive the configuration settings for multimedia messaging as a configuration message. See "Configuration settings service," p. 4. You can also enter the settings manually. See "Configuration," p. 48.

Select **Menu** > *Messaging* > *Message settings* > *Multimedia messages* and from the following options:

*Delivery reports* – to receive delivery reports about your messages (network service)

*MMS creation mode* – to restrict or allow various types of multimedia to be added to messages

*Image size in MMS* – to set the image size in multimedia messages

*Default slide timing* – to define the default time between slides in multimedia messages

*Allow MMS receptn.* – to allow or block a multimedia message. If you select *In home network*, you cannot receive multimedia messages when outside your home network. The default setting is generally *In home network*. The availability of this menu depends on your phone.

*Incoming MMS msgs.* – to decide how multimedia messages are retrieved. This setting is not shown if *Allow MMS receptn.* is set to *No*.

*Allow adverts* – to receive or reject advertisements. This setting is not shown if *Allow MMS receptn.* is set to *No*, or *Incoming MMS msgs.* is set to *Reject*.

*Configuration sett.* – to view the configurations that support multimedia messaging. Select a service provider, *Default*, or *Personal config.* for multimedia messaging. Select *Account* and a MMS account contained in the active configuration settings.

### E-mail messages

The e-mail settings affect the sending, receiving, and viewing of e-mail. You may receive the settings as a configuration message. See "Configuration settings service," p. 4. You can also enter the settings manually. See "Configuration," p. 48.

Select **Menu** > *Messaging* > *Message settings* > *E-mail messages*, and from the following options:

*New e-mail notif.* — to select whether a notification is shown when new e-mail is received

*Allow mail reception* — to select whether e-mail can be received when you are outside your home network

*Reply with orig. msg.* — to select whether the original message is included in the reply

*Image size in e-mail* — to select the size of images in e-mail

*Edit mailboxes* — to add new mailboxes or edit one in use

## 4. Contacts

You can save names and phone numbers (contacts) in the phone memory and in the SIM card memory.

### ■ Save names and phone numbers

Select **Menu** > *Contacts* > *Names* > **Options** > *Add new contact*. Names and numbers are saved in the phone memory.

### ■ Add contact details

Select **Menu** > *Contacts* > *Settings*, and ensure that the *Memory in use* is *Phone* or *Phone and SIM*. In the phone memory, you can save different types of phone numbers, a tone or a video clip, and short text items for a contact.

Search for the contact to which you want to add a detail, and select **Details** > **Options** > *Add detail*. Select from the available options.

### ■ Search for a contact

Select **Menu** > *Contacts* > *Names*. Scroll through the list of contacts, or enter the first characters of the name you are searching for.

### ■ Copy or move contacts

You can move and copy contacts from the phone memory to the SIM card memory or vice versa. The SIM card can save names with one phone number attached to them.

To move or copy all contacts, select **Menu** > *Contacts* > *Move contacts* or *Copy contacts*.

To move or copy contacts one by one, select **Menu** > *Contacts* > *Names*. Scroll to the contact, and select **Options** > *Move contact* or *Copy contact*.

To move or copy multiple contacts, select **Menu** > *Contacts* > *Names*. Scroll to a contact, and select **Options** > *Mark*. Mark the other contacts, and select **Options** > *Move marked* or *Copy marked*.

## ■ Edit contacts

Select **Menu** > *Contacts* > *Names*. Scroll to the contact, and select **Options** > *Edit*, and scroll to the details you want to change.

## ■ Groups

Select **Menu** > *Contacts* > *Groups* to arrange the names and phone numbers into caller groups with different ringing tones and group images.

## ■ Contact settings

Select **Menu** > *Contacts* > *Settings*, and from the following options:

*Memory in use* – See “Add contact details,” p. 29.

*Contacts view* – to select how the names and numbers in *Contacts* are displayed

*Name display* – to select whether the contact's first or last name is displayed first

## C o n t a c t s

*Font size* – to set the font size for the list of contacts

*Memory status* – to view the free and used memory capacity

## 5. Log

Select **Menu** > *Log* > *Missed calls*, *Received calls*, or *Dialled numbers*. To view your recent missed and received calls and dialled numbers chronologically, select *Call log*. To view the contacts to whom you most recently sent messages, select *Msg. recipients*.

To view how many text and multimedia messages you have sent and received, select **Menu** > *Log* > *Message log*.



**Note:** The actual invoice for calls and services from your service provider may vary, depending on network features, rounding off for billing, taxes, and so forth.

## 6. Settings

### ■ Profiles

Select **Menu** > *Settings* > *Profiles*, the desired profile, and from the following options:

*Activate* – to activate the selected profile

*Personalise* – to customise the profile with ringing tones, ringing volume, vibrating alerts, light effects, and message alert tones.

*Timed* – to set the profile to be active for a certain time up to 24 hours. After this time the previous profile becomes active.

### ■ Themes

Select **Menu** > *Settings* > *Themes*, and from the following options:

*Select theme* – to set a theme. A list of folders in *Gallery* opens. Open the *Themes* folder, and select a theme.

*Theme downloads* — to open a list of links to download more themes

## ■ Tones

Select **Menu** > *Settings* > *Tones*.

Select **Options** > *Save* to save the settings or *Cancel* to leave the settings unchanged.

If you select the highest ringing tone level, the ringing tone reaches its highest level after a few seconds.

## ■ Display

To personalise your display view, adjust the display settings.

## Standby mode settings

Select **Menu** > *Settings* > *Display*, and from the following options:

*Wallpaper* — to set your phone to display an image or a slide as wallpaper in the standby mode. Select *Wallpapers* >

## Settings

*Image or Slide set*, scroll to a folder, and select an image or slide set.

*Active standby* – to select whether the active standby mode is used.

*Standby font colour* – to select the colour for the texts on the display in the standby mode

*Navigation key icons* – to display the icons of the current scroll key shortcuts in the standby mode when active standby is off

*Notification details* – to show or hide details such as contact information, in both missed call and message received notifications

*Screen saver* – to display a shifting pattern or image when no function of the phone is used for a certain time

*Power saver* – to save battery power, a digital clock is displayed when no function of the phone is used for a certain time

*Sleep mode* – to save battery power, the display turns black when no function of the phone is used for a certain time

*Font size* – to set the font size for reading and writing messages, and viewing contacts and web pages

*Operator logo* – to set your phone to display or hide the operator logo, if available

*Cell info display* – to receive information from the network operator depending on the network cell used (network service)

## ■ Date and time

Select **Menu** > *Settings* > *Date and time* > *Date & time settings*, *Date and time format*, or *Auto-update of time* (network service) to change the time, time zone, and date settings.

## ■ My shortcuts

Personal shortcuts give you quick access to frequently used functions of the phone.

## Settings

### Left selection key

To select a function from the list, select **Menu** > *Settings* > *My shortcuts* > *Left selection key*.

### Right selection key

To select a function from the list, select **Menu** > *Settings* > *My shortcuts* > *Right selection key*.

### Navigation key

To assign other phone functions from a predefined list to the scroll key, select **Menu** > *Settings* > *My shortcuts* > *Navigation key*

### Active standby key

To select a function from the list, select **Menu** > *Settings* > *My shortcuts* > *Active standby key*.

## ■ Sync and backup

Select **Menu** > *Settings* > *Sync and backup*, to synchronise or copy data between your phone and another phone or remote server (network service).

*Phone switch* – to synchronise or copy data between two phones

*Create backup* – to create a backup of selected content and store it to your phone memory

*Restore backup* – to restore content previously backed up on your phone memory

*Server sync* – to synchronise data between your phone and a server

## ■ Connectivity

You can connect your phone to a compatible device using Bluetooth wireless technology or a USB data cable.

### Connecting with Bluetooth

This device is compliant with Bluetooth Specification 2.0 supporting the following profiles: advanced audio distribution, audio video remote control, dial-up networking, file transfer, generic access, generic object exchange, generic audio/video distribution<sup>9</sup>, hands-free, headset, object push, phonebook access, serial port, service discovery application, and SIM access. To ensure interoperability between other devices supporting Bluetooth technology, use Nokia approved enhancements for this model. Check with the manufacturers of other devices to determine their compatibility with this device.

Bluetooth technology allows you to connect your phone to a compatible Bluetooth phone within a 10 meter (33 feet) range. Since phones using Bluetooth technology communicate using radio waves, your phone and the other phones do not need to be in direct line of sight, although the connection can be subject to interference from obstructions, such as walls, or from other electronic devices.

Features using Bluetooth technology increase the demand on battery power and reduce the battery life.

## Activate a Bluetooth connection

Select **Menu** > *Settings* > *Connectivity* > *Bluetooth* > *On*.

Select *My phone's name*, to set or change the name of your phone that is visible to other Bluetooth devices.

 indicates that Bluetooth is active. Remember that Bluetooth uses battery power and may reduce battery life.

## Connect a Bluetooth device

Select **Menu** > *Settings* > *Connectivity* > *Bluetooth* > *Connect audio enhan.* and the device that you want to connect to.

## View a list of your Bluetooth connections

Select **Menu** > *Settings* > *Connectivity* > *Bluetooth* > *Active devices*.

### Send data to a Bluetooth device

Select **Menu** > *Settings* > *Connectivity* > *Bluetooth* > *Paired devices*. Select the device that you want to connect to, and enter a passcode. To connect to another device, you must agree on a passcode (up to 16 characters) to use. You only use the passcode once to set up the connection and begin transferring data.

If you do not see the device on the list, select **New** to list Bluetooth devices in range.

### Hide your Bluetooth device from others

Select **Menu** > *Settings* > *Connectivity* > *Bluetooth* > *My phone's visibility*. Select *Hidden*, or turn off Bluetooth completely.

### Synchronise from a compatible PC

To synchronise data from calendar, notes, and contacts, install the Nokia PC Suite software for your phone on a compatible PC. Use Bluetooth wireless technology or a USB

data cable, for the synchronisation, and start the synchronisation from the PC.

## Synchronise from a server

To use a remote internet server, subscribe to a synchronisation service. For more information and the settings required for this service, contact your service provider.

## USB data cable

You can use the USB data cable, CA-101, to transfer data between the phone and a compatible PC or a printer supporting PictBridge. You can also use the USB data cable with Nokia PC Suite.

*Ask on conn.* – to set your phone to ask whether to accept a connection

*PC Suite* – to use your phone to interact with applications on a PC that has Nokia PC Suite

## Settings

*Printing & Media* – to use your phone with a PictBridge compatible printer, or to connect your phone to a PC to synchronise it with Windows Media Player (music, video)

*Data storage* – to connect to a PC that does not have Nokia software and use your phone for data storage

To change the USB mode, select **Menu** > *Settings* > *Connectivity* > *USB data cable* > *Ask on conn.*, *PC Suite*, *Printing & Media*, or *Data storage*.

### ■ Call

Select **Menu** > *Settings* > *Call*, and from the following options:

*Call divert* – to divert your incoming calls (network service). You may not be able to divert your calls if some call barring functions are active. See *Call barring service* in "Access codes," p. xiv.

*Anykey answer > On* – to answer an incoming call by briefly pressing any key, except the power key, the left and right selection keys, or the end key

*Automatic redial* – to make a maximum of 10 attempts to connect the call after an unsuccessful call attempt

*Voice clarity* – to enhance speech intelligibility, especially in noisy environments

*Speed dialling* – See "Speed dialling," p. 15.

*Call waiting* – to receive a notification when you have an incoming call while you are on a call (network service).

*Summary after call* – to display the approximate duration and cost (network service) of the call after each call

*Send my caller ID* – to show your phone number to a person you are calling (network service). To use the setting agreed upon with your service provider, select *Set by network*.

*Video sharing* – to define video sharing settings

## ■ Phone

Select **Menu** > *Settings* > *Phone*, and from the following options:

*Language settings* – to set the display language of your phone, select *Phone language*. *Automatic* selects the

## Settings

language according to the information on the SIM card. To select the USIM card language, select *SIM language*. To set a language for the voice playback, select *Recognition lang..*

*Memory status* – to view the amount of used and available phone memory

*Automatic keyguard* – See "Access codes," p. xiv.

*Security keyguard* – See "Access codes," p. xiv.

*Voice recognition* – to make a phone call by saying the name that is saved in Contacts.

*Flight query* – See "Flight profile," p. 12.

*Welcome note* – to write the note that is shown when the phone is switched on

*Phone updates* – to update your phone software if there is an update available

*Network mode* – to select dual mode (UMTS or GSM). You cannot access this option during an active call.

*Operator selection* – to set the phone to automatically select one of the cellular networks available in your area,

select *Automatic*. With *Manual*, you can select a network that has a roaming agreement with your service provider.

*Help text activation* – to select whether the phone shows help texts

*Start-up tone* – to select whether the phone plays a tone when it is switched on

## ■ Enhancements

This menu or the following options are shown if the phone is, or has been, connected to a compatible mobile enhancement.

Select **Menu** > *Settings* > *Enhancements*. Select an enhancement and, depending on the enhancement, from the following options:

*Default profile* – to select the profile that you want to be automatically activated when you connect to the selected enhancement

*Automatic answer* – to set the phone to answer an incoming call automatically after 5 seconds. If **Menu** >

## Settings

*Settings > Tones > Incoming call alert* is set to *Beep once* or *Off*, automatic answer is off.

### ■ Configuration

You can configure your phone with settings that are required for certain services to function correctly. Your service provider may also send you these settings as a configuration message.

Select **Menu** > *Settings* > *Configuration* and from the following options:

*Default config. sett.* – to view the service providers saved in the phone. To set the configuration settings of the service provider as default settings, select **Options** > *Set as default*.

*Activ. def. in all apps.* – to activate the default configuration settings for supported applications

*Preferred access pt.* – to view the saved access points. Scroll to an access point, and select **Options** > *Details To*

view the name of the service provider, data bearer, and packet data access point or GSM dial-up number.

*Connect to support* – to download the configuration settings from your service provider

*Personal config. sett.* – to add new personal accounts for various services manually, and to activate or delete them. The parameters differ according to the selected service type.

## ■ Restore factory settings

To reset some of the menu settings to their original values, select **Menu** > *Settings* > *Rest. factory sett.* Enter the security code. The names and phone numbers saved in *Contacts* are not deleted.

## ■ Phone software updates

Your service provider may send phone software updates over the air directly to your device. This option may not be available, depending on your phone.

## Settings



**Warning:** If you install a software update, you cannot use the device, even to make emergency calls, until the installation is completed and the device is restarted. Be sure to back up data before accepting installation of an update.

## 7. PC connectivity

You can send and receive e-mail, and access the internet when your phone is connected to a compatible PC through a Bluetooth connection or a data cable. You can use your phone with a variety of PC connectivity and data communications applications.

### ■ Nokia PC Suite

With Nokia PC Suite, you can synchronise contacts, calendar, notes, and to-do notes between your phone and a compatible PC or a remote internet server (network service). You may find more information and PC Suite at [www.nokia-asia.com/3120classic/support](http://www.nokia-asia.com/3120classic/support) or your local Nokia website.

### ■ Data communication applications

For information on using a data communication application, refer to the documentation provided with it.

## PC connectivity

Making or answering phone calls during a computer connection is not recommended, as it might disrupt the operation.

For better performance during data calls, place the phone on a stationary surface with the keypad facing downward. Do not move the phone by holding it in your hand during a data call.

## 8. Media

You can take photos or record live video clips with the built-in 2.0-megapixel camera.

### ■ Camera

The camera produces pictures in .jpg format, and you can digitally zoom up to eight times.

### Take an image

Select **Menu** > *Media* > *Camera* > **Capture**. To take another image, select **Back**; to send the image as a multimedia message, select **Send**. Your phone saves the image in *Gallery* > *Images*.

To zoom in or out, press the volume key up or down.

### ■ Video

You can record video clips in .3gp or .mp4 format.

## Media

To set the quality of your video clips, select **Menu** > *Media* > *Video* > **Options** > *Settings* > *Video clip quality* > *High*, *Normal*, or *Basic*.

To select the file size limit, select **Menu** > *Media* > *Video* > **Options** > *Settings* > *Video clip length*.

## Record a video clip

Select **Menu** > *Media* > *Video* > **Record**. To zoom in or out, press the volume key up or down.

## ■ Music player

Your phone includes a music player for listening to music tracks, recordings, or other MP3, MPEG4, AAC, eAAC+, or WMA music files that you have transferred to the phone with the Nokia Audio Manager application, which is part of Nokia PC Suite.





To open the music player, select **Menu** > *Media* > *Music player*.

## Radio





The FM radio depends on an antenna other than the wireless device antenna. A compatible headset or enhancement needs to be attached to the device for the FM radio to function properly.



**Warning:** Listen to music at a moderate level. Continuous exposure to high volume may damage your hearing. Do not hold the device near your ear when the loudspeaker is in use, because the volume may be extremely loud.

Select **Menu** > *Media* > *Radio*. To use the graphical keys , , , or  on the display, scroll left or right to the key you want, and select it.

## Save stations

1. To search for radio stations, select and hold  or . To change the radio frequency in 0.05 MHz steps, press  or .

## Media

2. To save the station to a memory location, choose **Options** and select *Save station*.
3. To name a saved station, choose **Options** > *Stations*, select the station, **Options** > *Rename* and enter a name.

## Listen

1. Select **Menu** > *Media* > *Radio*.
2. To scroll to the radio station you want, select ▲ or ▼, or press the headset key.
3. To select a radio station location, briefly press the corresponding number keys.
4. Select **Options** and one of the following options:
  - Switch off* – to turn off the radio
  - Save station* – to save a new radio station by entering the station's name. This option is only displayed when the selected radio station is not saved.

*Stations* – to select a saved station from the list. It is only possible to enter the station list if the selected station has been previously saved.

*Search all stations* – to search for all radio stations that the phone can receive

*Set frequency* – to enter the frequency of the radio station.

*Settings* – to change the radio default settings.

*Station directory* – to access Visual Radio web pages.

*Visual Radio* – to set whether the Visual Radio application is used. Some radio channels may send text or graphical information that you can view using Visual Radio.

*Enable visual service* – to set whether the Visual Radio application starts automatically when you turn on the radio

You can normally make a call or answer an incoming call while listening to the radio. During the call, the volume of the radio is muted.

## Media

When an application using a packet data or HSCSD connection is sending or receiving data, it may interfere with the radio.

## 9. Battery and charger information

Your device is powered by a rechargeable battery. The battery intended for use with this device is BL-4U. This device is intended for use when supplied with power from the following chargers: AC-3. The battery can be charged and discharged hundreds of times, but it will eventually wear out. When the talk and standby times are noticeably shorter than normal, replace the battery. Use only Nokia approved batteries, and recharge your battery only with Nokia approved chargers designated for this device. Use of an unapproved battery or charger may present a risk of fire, explosion, leakage, or other hazard.

If a battery is being used for the first time or if the battery has not been used for a prolonged period, it may be necessary to connect the charger, then disconnect and reconnect it to begin charging the battery. If the battery is completely discharged, it may take several minutes before

## Battery and charger information

the charging indicator appears on the display or before any calls can be made.

Always switch the device off and disconnect the charger before removing the battery.

Unplug the charger from the electrical plug and the device when not in use. Do not leave a fully charged battery connected to a charger, since overcharging may shorten its lifetime. If left unused, a fully charged battery will lose its charge over time.

Always try to keep the battery between 15°C and 25°C (59°F and 77°F). Extreme temperatures reduce the capacity and lifetime of the battery. A device with a hot or cold battery may not work temporarily. Battery performance is particularly limited in temperatures well below freezing.

Do not short-circuit the battery. Accidental short-circuiting can occur when a metallic object such as a coin, clip, or pen causes direct connection of the positive (+) and negative (-) terminals of the battery. (These look like metal strips on the battery.) This might happen, for example, when you carry a

## Battery and charger information

spare battery in your pocket or purse. Short-circuiting the terminals may damage the battery or the connecting object.

Do not dispose of batteries in a fire as they may explode. Batteries may also explode if damaged. Dispose of batteries according to local regulations. Please recycle when possible. Do not dispose as household waste.

Do not dismantle, cut, open, crush, bend, deform, puncture, or shred cells or batteries. In the event of a battery leak, do not allow the liquid to come in contact with the skin or eyes. In the event of such a leak, flush your skin or eyes immediately with water, or seek medical help.

Do not modify, remanufacture, attempt to insert foreign objects into the battery, or immerse or expose it to water or other liquids.

Improper battery use may result in a fire, explosion, or other hazard. If the device or battery is dropped, especially on a hard surface, and you believe the battery has been damaged, take it to a service centre for inspection before continuing to use it.

## Battery and charger information

Use the battery only for its intended purpose. Never use any charger or battery that is damaged. Keep your battery out of the reach of small children.

### ■ **Nokia battery authentication guidelines**

Always use original Nokia batteries for your safety. To check that you are getting an original Nokia battery, purchase it from an authorised Nokia dealer, and inspect the hologram label using the following steps:

Successful completion of the steps is not a total assurance of the authenticity of the battery. If you have any reason to believe that your battery is not an authentic, original Nokia battery, you should refrain from using it. If authenticity cannot be verified, return the battery to the place of purchase.

## Battery and charger information

### Authenticate hologram

1. When you look at the hologram on the label, you should see the Nokia connecting hands symbol from one angle and the Nokia Original Enhancements logo when looking from another angle.
2. When you angle the hologram left, right, down and up, you should see 1, 2, 3 and 4 dots on each side respectively.



### What if your battery is not authentic?

If you cannot confirm that your Nokia battery with the hologram on the label is an authentic Nokia battery, please do not use the battery. The use of a battery that is not

## Battery and charger information

approved by the manufacturer may be dangerous and may result in poor performance and damage to your device and its enhancements. It may also invalidate any approval or warranty applying to the device.

To find out more about original Nokia batteries, visit [www.nokia-asia.com/batterycheck](http://www.nokia-asia.com/batterycheck).

## 10. Nokia original enhancements

An extensive range of enhancements is available for your phone. Please visit [www.nokia-asia.com/enhancements](http://www.nokia-asia.com/enhancements) for more details.



For availability of the enhancements, please check with your local dealer. A few practical rules for enhancements operation:

- Keep the enhancements out of small children's reach.
- When you disconnect the power cord of any accessory, grasp and pull the plug, not the cord.
- Check regularly that all mobile phone equipment in a vehicle is mounted and operating properly.

**Use only batteries, chargers and enhancements approved by the phone manufacturer. The use of any other types may invalidate any approval or warranty applying to the phone, and may be dangerous.**

## ■ BATTERY

Type	Talktime#	Standby#
BL-4U	up to 3 hours 20 minutes (GSM); up to 2 hours 45 minutes (WCDMA)	up to 300 hours

# Variation in operation times may occur depending on SIM card, network and usage settings, usage style and environments. Use of FM radio and integrated hands-free will affect talktime and standby.

## ■ Headsets

### Wireless Headsets

#### **Nokia Bluetooth Headset BH-209**

With the Nokia Bluetooth Headset BH-209 it's easy to handle calls on the move. Comfortably small and light, it's an easy to wear handsfree headset that fits either ear. And,

it's a snap to use with a single button control, simple interface, and volume control via your device.

## Wired Headsets

### **Nokia Stereo Headset HS-47**

An automatic mute function when receiving a call on these stereo headphones ensures you won't miss a thing.

## ■ Car Solutions

### Plug-in Solution

#### **Nokia Speakerphone HF-300**

This handsfree solution clips onto your car's sun visor - conveniently placed so you can talk and listen. Unclip it and you can easily use it as a speakerphone at the office or in the home. A powerful, yet compact speaker and sensitive microphone provide high-quality sound so you can hear and be heard clearly. Its interface is easy to use, and the keys are illuminated so you can find the keys quickly - day or night.

## ■ Data

### Memory Cards

#### **Nokia 2 GB microSD Card MU-37**

This compact 2GB microSD memory card lets you store large amounts of data, music and software applications on your phone.

## Care and maintenance

Your device is a product of superior design and craftsmanship and should be treated with care. The following suggestions will help you protect your warranty coverage.

- Keep the device dry. Precipitation, humidity, and all types of liquids or moisture can contain minerals that will corrode electronic circuits. If your device does get wet, remove the battery, and allow the device to dry completely before replacing it.
- Do not use or store the device in dusty, dirty areas. Its moving parts and electronic components can be damaged.
- Do not store the device in hot areas. High temperatures can shorten the life of electronic devices, damage batteries, and warp or melt certain plastics.
- Do not store the device in cold areas. When the device returns to its normal temperature, moisture can form inside the device and damage electronic circuit boards.
- Do not attempt to open the device other than as instructed in this guide.

## Care and maintenance

- Do not drop, knock, or shake the device. Rough handling can break internal circuit boards and fine mechanics.
- Do not use harsh chemicals, cleaning solvents, or strong detergents to clean the device.
- Do not paint the device. Paint can clog the moving parts and prevent proper operation.
- Use a soft, clean, dry cloth to clean any lenses, such as camera, proximity sensor, and light sensor lenses.
- Use only the supplied or an approved replacement antenna. Unauthorised antennas, modifications, or attachments could damage the device and may violate regulations governing radio devices.
- Use chargers indoors.
- Always create a backup of data you want to keep, such as contacts and calendar notes.
- To reset the device from time to time for optimum performance, power off the device and remove the battery.

These suggestions apply equally to your device, battery, charger, or any enhancement. If any device is not working properly, take it to the nearest authorised service facility for service.

## Additional safety information

### ■ Small children

Your device and its enhancements may contain small parts. Keep them out of the reach of small children.

### ■ Operating environment

This device meets RF exposure guidelines when used either in the normal use position against the ear or when positioned at least 1.5 centimeters (5/8 inch) away from the body. When a carry case, belt clip, or holder is used for body-worn operation, it should not contain metal and should position the device the above-stated distance from your body.

To transmit data files or messages, this device requires a quality connection to the network. In some cases, transmission of data files or messages may be delayed until such a connection is available. Ensure the above separation distance instructions are followed until the transmission is completed.

Parts of the device are magnetic. Metallic materials may be attracted to the device. Do not place credit cards or other magnetic

## **A d d i t i o n a l   s a f e t y   i n f o r m a t i o n**

storage media near the device, because information stored on them may be erased.

### **■ Medical devices**

Operation of any radio transmitting equipment, including wireless phones, may interfere with the functionality of inadequately protected medical devices. Consult a physician or the manufacturer of the medical device to determine if they are adequately shielded from external RF energy or if you have any questions. Switch off your device in health care facilities when any regulations posted in these areas instruct you to do so. Hospitals or health care facilities may be using equipment that could be sensitive to external RF energy.

### **Implanted medical devices**

Manufacturers of medical devices recommend that a minimum separation of 15.3 centimeters (6 inches) should be maintained between a wireless device and an implanted medical device, such as a pacemaker or implanted cardioverter defibrillator, to avoid potential interference with the medical device. Persons who have such devices should:

- Always keep the wireless device more than 15.3 centimeters (6 inches) from the medical device when the wireless device is turned on.

## Additional safety information

- Not carry the wireless device in a breast pocket.
- Hold the wireless device to the ear opposite the medical device to minimise the potential for interference.
- Turn the wireless device off immediately if there is any reason to suspect that interference is taking place.
- Read and follow the directions from the manufacturer of their implanted medical device.

If you have any questions about using your wireless device with an implanted medical device, consult your health care provider.

### Hearing aids

Some digital wireless devices may interfere with some hearing aids. If interference occurs, consult your service provider.

### ■ Vehicles

RF signals may affect improperly installed or inadequately shielded electronic systems in motor vehicles such as electronic fuel injection systems, electronic antiskid (antilock) braking systems, electronic speed control systems, and air bag systems. For more information, check with the manufacturer, or its representative, of your vehicle or any equipment that has been added.

## **A d d i t i o n a l   s a f e t y   i n f o r m a t i o n**

Only qualified personnel should service the device or install the device in a vehicle. Faulty installation or service may be dangerous and may invalidate any warranty that may apply to the device. Check regularly that all wireless device equipment in your vehicle is mounted and operating properly. Do not store or carry flammable liquids, gases, or explosive materials in the same compartment as the device, its parts, or enhancements. For vehicles equipped with an air bag, remember that air bags inflate with great force. Do not place objects, including installed or portable wireless equipment in the area over the air bag or in the air bag deployment area. If in-vehicle wireless equipment is improperly installed and the air bag inflates, serious injury could result.

Using your device while flying in aircraft is prohibited. Switch off your device before boarding an aircraft. The use of wireless teledevices in an aircraft may be dangerous to the operation of the aircraft, disrupt the wireless telephone network, and may be illegal.

### **■ Potentially explosive environments**

Switch off your device when in any area with a potentially explosive atmosphere, and obey all signs and instructions. Potentially explosive atmospheres include areas where you would normally be advised to turn off your vehicle engine. Sparks in such areas could cause an explosion or fire resulting in bodily injury or even death.

## Additional safety information

Switch off the device at refuelling points such as near gas pumps at service stations. Observe restrictions on the use of radio equipment in fuel depots, storage, and distribution areas; chemical plants; or where blasting operations are in progress. Areas with a potentially explosive atmosphere are often, but not always, clearly marked. They include below deck on boats, chemical transfer or storage facilities and areas where the air contains chemicals or particles such as grain, dust, or metal powders. You should check with the manufacturers of vehicles using liquefied petroleum gas (such as propane or butane) to determine if this device can be safely used in their vicinity.

### ■ Emergency calls



**Important:** This device operates using radio signals, wireless networks, landline networks, and user-programmed functions. If your device supports voice calls over the internet (internet calls), activate both the internet calls and the cellular phone. The device will attempt to make emergency calls over both the cellular networks and through your internet call provider if both are activated. Connections in all conditions cannot be guaranteed. You should never rely solely on any wireless device for essential communications like medical emergencies.

## **A d d i t i o n a l   s a f e t y   i n f o r m a t i o n**

### **To make an emergency call:**

1. If the device is not on, switch it on. Check for adequate signal strength. Depending on your device, you may also need to complete the following:
  - Insert a SIM card if your device uses one.
  - Remove certain call restrictions you have activated in your device.
  - Change your profile from offline or flight profile mode to an active profile.
2. Press the end key as many times as needed to clear the display and ready the device for calls.
3. Enter the official emergency number for your present location. Emergency numbers vary by location.
4. Press the call key.

When making an emergency call, give all the necessary information as accurately as possible. Your wireless device may be the only means of communication at the scene of an accident. Do not end the call until given permission to do so.

### ■ Certification information (SAR)

This mobile device meets guidelines for exposure to radio waves.

Your mobile device is a radio transmitter and receiver. It is designed not to exceed the limits for exposure to radio waves recommended by international guidelines. These guidelines were developed by the independent scientific organization ICNIRP and include safety margins designed to assure the protection of all persons, regardless of age and health.

The exposure guidelines for mobile devices employ a unit of measurement known as the Specific Absorption Rate or SAR. The SAR limit stated in the ICNIRP guidelines is 2.0 watts/kilogram (W/kg) averaged over 10 grams of tissue. Tests for SAR are conducted using standard operating positions with the device transmitting at its highest certified power level in all tested frequency bands. The actual SAR level of an operating device can be below the maximum value because the device is designed to use only the power required to reach the network. That amount changes depending on a number of factors such as how close you are to a network base station. The highest SAR value under the ICNIRP guidelines for use of the device at the ear is 0.98 W/kg for RM-364 and 0.95 W/kg for RM-365, and 0.69 W/kg for RM-366.

## **A d d i t i o n a l   s a f e t y   i n f o r m a t i o n**

Use of device accessories and enhancements may result in different SAR values. SAR values may vary depending on national reporting and testing requirements and the network band. Additional SAR information may be provided under product information at [www.nokia.com](http://www.nokia.com).

# MANUFACTURER'S LIMITED WARRANTY

NOTE! This Limited Warranty is in addition to, and does not affect your legal (statutory) rights under your applicable national laws relating to the sale of consumer products.

Nokia Corporation ("Nokia") provides this Limited Warranty to person who has purchased the Nokia product(s) included in the sales package ("Product").

Nokia warrants to you that during the warranty period Nokia or a Nokia authorized service company will in a commercially reasonable time remedy defects in materials, design and workmanship free of charge by repairing or, should Nokia in its absolute discretion deem it necessary, replacing the Product in accordance with this Limited Warranty (unless otherwise required by law). This Limited Warranty is only valid and enforceable in the country where you have purchased the Product provided that it is intended for sale in that country.

## ***Warranty Period***

The warranty period starts at the time of Product's original purchase by the first end-user. The Product may consist of several different parts and different parts may be covered by a different warranty period (hereinafter "Warranty Period"). The different Warranty Periods are:

- a) twelve (12) months for the mobile device and accessories (whether included in the mobile device sales package or sold separately) other than the consumable parts and accessories listed in (b) and (c) below;

## MANUFACTURER'S LIMITED WARRANTY

- b) six (6) months for the following consumable parts and accessories: batteries, chargers, desk stands, headsets, cables and covers; and
- c) ninety (90) days for the media on which any software is provided, e.g. CD-rom, memory card.

As far as your national laws permit, the Warranty Period will not be extended or renewed or otherwise affected due to subsequent resale, repair or replacement of the Product. However, repaired part(s) will be warranted for the remainder of the original Warranty Period or for sixty (60) days from the date of repair, whichever is longer.

### ***How to get warranty service.***

If you wish to make a claim under the Limited Warranty, you may call the Nokia call center (where this is available and please note national rates apply to calls) and/or where necessary, return your Product or the affected part (if it is not the entire Product) to a Nokia care center or Nokia designated service location. Information about Nokia care centers, Nokia designated service locations and Nokia call centers can be found at local Nokia web pages where available.

You must return your Product or the affected part (if it is not the entire Product) to a Nokia care center or Nokia designated service location before the expiry of the Warranty Period.

When making a Limited Warranty claim you have to present: a) the Product (or affected part thereto), b) the legible and unmodified original proof of purchase, which clearly indicates the name and address of the seller, the date and place of purchase, the product type and the IMEI or other serial number.

This Limited Warranty extends only to the original first end-user of the Product and is not assignable or transferable to any subsequent purchaser/end-user.

## MANUFACTURER'S LIMITED WARRANTY

### *What is not covered?*

1. This Limited Warranty does not cover user manuals or any third party software, settings, content, data or links, whether included/ downloaded in the Product, whether included during installment, assembly, shipping or at any other time in the delivery chain or otherwise and in any way acquired by you. To the extent permitted by applicable law(s), Nokia does not warrant that any Nokia software will meet your requirements, will work in combination with any hardware or software applications provided by a third party, that the operation of the software will be uninterrupted or error free or that any defects in the software are correctable or will be corrected.
2. This Limited Warranty does not cover a) normal wear and tear (including, without limitation, wear and tear of camera lenses, batteries or displays), b) transport costs, c) defects caused by rough handling (including, without limitation, defects caused by sharp items, by bending, compressing or dropping, etc.), d) defects or damage caused by misuse of the Product, including use that is contrary to the instructions provided by Nokia (e.g. as set out in the Product's user guide) and/or e) other acts beyond the reasonable control of Nokia.
3. This Limited Warranty does not cover defects or alleged defects caused by the fact that the Product was used with, or connected to, a product, accessories, software and/or service not manufactured, supplied or authorized by Nokia or was used otherwise than for its intended use. Defects can be caused by viruses from your or from a third party's unauthorised access to services, other accounts, computer systems or networks. This unauthorised access can take place through hacking, password-mining or through a variety of other means.

## MANUFACTURER'S LIMITED WARRANTY

4. This Limited Warranty does not cover defects caused by the fact that the battery has been short-circuited or by the fact that the seals of the battery enclosure or the cells are broken or show evidence of tampering or by the fact that the battery has been used in equipment other than those for which it has been specified.
5. This Limited Warranty does not apply if the Product has been opened, modified or repaired by anyone other than an authorized service centre, if it is repaired using unauthorised spare parts or if the Product's serial number, the mobile accessory date code or the IMEI number has been removed, erased, defaced, altered or are illegible in any way and this shall be determined in the sole discretion of Nokia.
6. This Limited Warranty does not apply if the Product has been exposed to moisture, to dampness or to extreme thermal or environmental conditions or to rapid changes in such conditions, to corrosion, to oxidation, to spillage of food or liquid or to influence from chemical products.

### ***Other important notices***

A third party, independent operator provides the SIM card and cellular and/or other network or system on which the Product operates. Therefore, Nokia will not accept responsibility under this warranty for the operation, availability, coverage, services or range of the cellular or other network or system. Before the Product can be repaired or replaced, the operator may need to unlock any SIM-lock or other lock that may have been added to lock the product to a specific network or operator. Accordingly, Nokia does not accept responsibility for any delays in warranty repairs or for the inability of Nokia to complete warranty repairs that are caused by the operator's delay or failure to unlock any SIM-lock or other lock.

## MANUFACTURER'S LIMITED WARRANTY

Please remember to make back-up copies or keep written records of all important content and data stored in your Product, because content and data may be lost during repair or replacement of the Product. Nokia, in a manner consistent with the provisions of the section entitled "Limitation of Nokia's Liability" below, to the extent permitted by applicable law(s), shall not under any circumstances be liable, either expressly or impliedly, for any damages or losses of any kind whatsoever resulting from loss of, damage to, or corruption of, content or data during repair or replacement of the Product.

All parts of the Product or other equipment that Nokia has replaced shall become the property of Nokia. If the returned Product is found not to be covered by the terms and conditions of the Limited Warranty, Nokia and its authorized service companies reserve the right to charge a handling fee. When repairing or replacing the Product, Nokia may use products or parts that are new, equivalent to new or re-conditioned.

Your Product may contain country specific elements, including software. If the Product has been re-exported from its original destination country to another country, the Product may contain country specific elements that are not considered to be a defect under this Limited Warranty.

### *Limitation of Nokia's liability*

This Limited Warranty is your sole and exclusive remedy against Nokia and Nokia's sole and exclusive liability in respect of defects in your Product. However, this Limited Warranty shall neither exclude nor limit i) any of your legal (statutory) rights under the applicable national laws or ii) any of your rights against the seller of the Product.

This Limited Warranty replaces all other Nokia warranties and liabilities, whether oral, written, (non-mandatory) statutory, contractual, in tort or otherwise, including, without limitation, and where permitted by applicable law, any implied conditions, warranties or other terms as to

## MANUFACTURER'S LIMITED WARRANTY

satisfactory quality or fitness for purpose. To the extent permitted by applicable law(s) Nokia does not assume any liability for loss of or damage to or corruption of data, for any loss of profit, loss of use of Products or functionality, loss of business, loss of contracts, loss of revenues or loss of anticipated savings, increased costs or expenses or for any indirect loss or damage, consequential loss or damage or special loss or damage. To the extent permitted by applicable law, Nokia's liability shall be limited to the purchase value of the Product. The above limitations shall not apply to death or personal injury resulting from Nokia's proven negligence.

### ***Statutory obligations***

This Limited Warranty must be read subject to any statutory provisions that imply warranties or conditions into this Limited Warranty that cannot be excluded, restricted or modified or cannot be excluded, restricted or modified except to a limited extent. If such statutory provisions apply, to the extent to which Nokia is able to do so, its liability under those provisions will be limited, at its option to, in the case of goods: the replacement of the goods or the supply of equivalent goods, the repair of the goods, the payment of the cost of replacing the goods or of acquiring equivalent goods, or the payment of the cost of having the goods repaired; and in the case of services: the supplying of the services again or the payment of the cost of having the services supplied again.

**NOTE!** Your Product is a sophisticated electronic device. Nokia strongly encourages you to familiarize yourself with the user guide and instructions provided with and for the Product. Please also note that the Product might contain high precision displays, camera lenses and other such parts, which could be scratched or otherwise damaged if not handled very carefully.

## MANUFACTURER'S LIMITED WARRANTY

All warranty information, product features and specifications are subject to change without notice.

Nokia Corporation  
Keilalahdentie 2-4  
FIN-02150 Espoo  
Finland

## Index

### A

access codes xiv  
antenna 5

### B

BATTERY 66  
battery  
Bluetooth 40

### C

call  
    log 33  
    register. See call log.  
calls  
    international 14  
    making 14  
    options 16  
    settings 44  
camera 53  
charge level 10  
codes xiv

configurations  
    general 48  
    setting service 4  
contacts  
    copying 30  
    editing 31  
    groups 31  
    saving 29  
    searching 30  
    settings 31  
    speed dialling 15

### D

data communication 51  
downloads xvii

### E

e-mail application 21  
ending calls 14

**F**

factory settings 49  
flight mode 12  
front camera 6

**H**

handsfree. See loudspeaker.

**I**

images 53  
indicators 11

**L**

language settings 45  
log 33  
loudspeaker 7

**M**

MANUFACTURER'S LIMITED  
WARRANTY 79  
message settings  
    e-mail 28  
    general 24

multimedia  
messages 26  
text messages 25

**N**

Nokia original  
enhancements 65

**O**

operator logo 10, 37

**P**

PC connectivity 51  
PC Suite 51  
power key 3  
profiles 34

**R**

radio 55  
ringing tones 35

**S**

safety information ix

## Index

### settings

- call 44

- configuration 48

- connectivity 39

- messages 24

- my shortcuts 37

- phone 45

- profiles 34

- restore factory

- settings 49

- themes 34

- tones 35

shortcuts 37

signal strength 10

software updates xvi

speed dialling 15

standby mode 9

switch on and off 3

## T

themes 34

tones 35

## U

unlock the keypad xiv

# Nokia Care Online

The Nokia Care web support provides you with more information on our online services.



## INTERACTIVE DEMONSTRATIONS

Learn how to set up your phone for the first time, and find out more about its features. Interactive Demonstrations give step-by-step instructions on using your phone.



## USER'S GUIDE

The online User's Guide contains detailed information on your phone. Remember to check regularly for updates.



## SOFTWARE

Make the most of your phone with software for your phone and PC. Nokia PC Suite connects your phone and PC so you can manage your calendar, contacts, music and images, while other applications complement its use.



## SETTINGS

Certain phone functions, such as multimedia messaging, mobile browsing and email\*, may require settings before you can use them. Have them sent to your phone free of charge.

\*Not available on all phones.

Please visit your own country site for more details:

**Australia and New Zealand**

[www.nokia.com.au/support](http://www.nokia.com.au/support)

**India**

[www.nokia.co.in/support](http://www.nokia.co.in/support)

**Indonesia**

[www.nokia.co.id/support](http://www.nokia.co.id/support)

**Japan**

[www.nokia.co.jp/support](http://www.nokia.co.jp/support)

**Malaysia**

[www.nokia.com.my/support](http://www.nokia.com.my/support)

**Philippines**

[www.nokia.com.ph/support](http://www.nokia.com.ph/support)

**Singapore**

[www.nokia.com.sg/support](http://www.nokia.com.sg/support)

**Thailand**

[www.nokia.co.th/support](http://www.nokia.co.th/support)

**Vietnam**

[www.nokia.com.vn/support](http://www.nokia.com.vn/support)

If your country is not listed above, please visit [www.nokia-asia.com/support](http://www.nokia-asia.com/support).

**NOKIA**

*Care*